

# Fitting Instructions

1

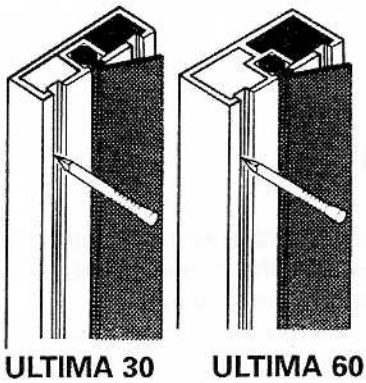

## ULTIMA30 (FD30S)

- 30 minute fire and smoke seals

## ULTIMA60 (FD60S)

- 60 minute fire and smoke seals

For single-acting single leaf 30 minutes and 60 minutes fire doors

### ULTIMA30 on single leaf 30 minutes doors

This seal (Fig 1) can be rebated into the head and jambs of the door frame, usually in line with the centre of the door edge. (Fig 2) Alternatively it may be rebated into the top rail and stiles of the door. (Figs 3 and 4) Either method gives equally effective protection against fire penetration. Carefully note the direction in the blades point. The seal is broken at the hinges and the lock/latch plate. These areas are protected by Sealmaster Intumescent Plugs. (See separate data sheet).

### ULTIMA60 on single leaf 60 minutes doors

This seal (Fig 1) may be rebated into the head and jambs of the door frame (Fig 6) or in the top rail and stiles of the door. (Figs 7 and 8).

It is most important that the correct width and depth of rebate is cut, as remedial work can be costly in time and money. The sizes given here take into account acceptable variations in tolerances of extrusions.

2

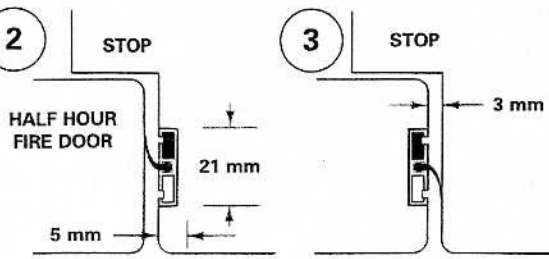

4

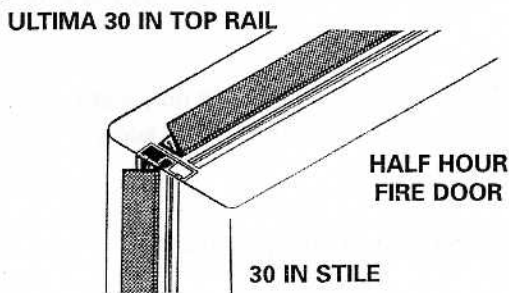

SEAL	EXTRUSION WIDTH	EXTRUSION DEPTH
ULTIMA30	21 mm	5 mm
ULTIMA60	21 mm	7.5 mm

We recommend that the groove be routed to give a 'light press fit' for the extrusion. The seal should finish flush with the timber.

The recommended door-to-door gap and door-to-frame gap is 3mm.

5

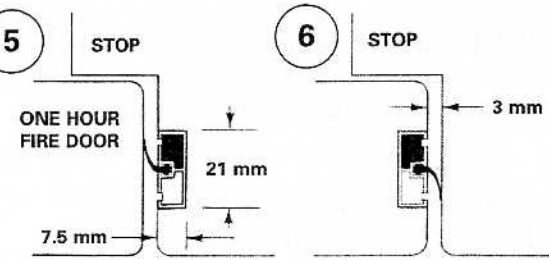

7

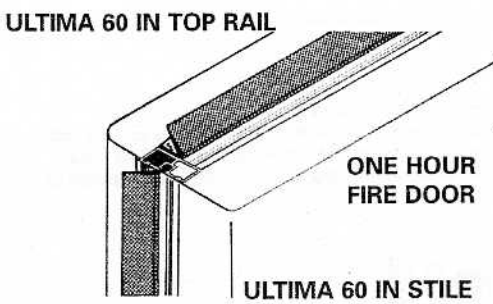

Intumescent strips are supplied in standard lengths of 1050mm. Short ends, resulting from cutting to fit, can be used butted up to each other. Cut ends require no treatment. Strips should be pinned every 200mm or as required.

All corners of timber components must be well rounded to prevent damage to the insert and ensure ease of adjustment. Contact surfaces for the blade should be finished, smooth and fair. 'NIP' aluminium carrier onto base of insert to prevent it slipping out.

Solvent based glues, paints, varnishes, etc must not come into contact with neoprene inserts.

The information given here is based on our general experience and tests and is intended for guidance only. Every effort is made to ensure that the data on this instruction sheet is correct and we do not accept liability for the injury, loss or damage arising from reliance thereon. This data sheet does not form part of a contract and any difficulties arising from on-site conditions should be referred to our engineers for advice.



**Sealmaster**  
Pampisford Cambridge CB2 4HG  
Tel: 01223 832851 Fax: 01223 837215